

# Fujitsu focus

The News on the Latest Semiconductor Technologies and Products from Fujitsu Microelectronics America, Inc.

## The Fujitsu Mobile WiMAX SoC

The Fujitsu MB86K21 802.16e provides substantial speed, power consumption and latency performance advantages over comparable market alternatives, in a compact form factor. The SoC is targeted to be the first in its class to participate in WiMAX Forum Wave 2 certification. Samples will be available this August. **See page 2.**

<http://us.fujitsu.com/micro/Wimax>



## Kedah Selects the Fujitsu Fixed WiMAX SoC for 3.5GHz Wireless Systems in Russia

Fujitsu is providing its MB87M3550 fixed WiMAX SoCs to Kedah Electronics Engineering, an entrepreneurial Russian company. Kedah will use the SoCs for its new AsterPlex+ WiMAX CPE and WiMAX base stations. Kedah plans to ship systems for the 3.5GHz band this year, and to expand into 2.5 – 2.7GHz and 5.1 – 6.4GHz thereafter.

**See page 2.** <http://us.fujitsu.com/micro/Wimax>



## A Whitepaper: Fixed WiMAX Applications Focus on IP Video Surveillance Networks

A new Fujitsu whitepaper details how WiMAX innovation is improving the performance and affordability of next-generation wireless IP video surveillance systems. Emerging and maturing wireless technologies now enable cost-effective commercial surveillance systems to be adopted in areas where traditionally such systems were impossible or impractical. **See page 3.** <http://www.fujitsu.com/us/services/edevices/microelectronics/wipvideo.html>



## The Fujitsu 20-port, 10GbE Switch Chip, MB8AA3020

The Fujitsu 20-port, 10GbE switch chip delivers 400+Gbps non-blocking, aggregate switching bandwidth, along with high QoS, for data center and carrier networks. Features like VLAN virtualization, backward congestion-management notification (BCN), priority-based PAUSE, the smallest-in-class footprint and low power consumption equip the MB8AA3020 for server blade and other bladed configurations like microTCA, ATCA blade and carrier blade applications. **See page 3.** <http://us.fujitsu.com/micro/10gethernet>



## Teranetics, Teak and CorEdge Showcase 10Gbps Ethernet Technologies at Interop West 2007

Leading communication companies are increasingly using the Fujitsu 20-port, 10Gbps Ethernet switch chip to meet the needs of challenging server, data-center, MCH and other networking applications. Three of these companies are demonstrating their high-performance networking products at Interop West 2007. **See page 3.**

<http://us.fujitsu.com/micro/10gethernet>

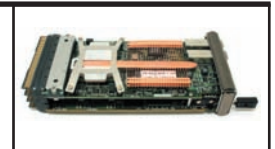

## Gennum and Fujitsu Demonstration at Interop West 2007

Gennum and Fujitsu are jointly demonstrating SFP+ capability using the Fujitsu 20-port, 10GbE switch chip and Gennum's CDR ICs. The innovative 10Gbps serial interconnect, based on the Fujitsu MB8AA3020, connects directly to an SFP+ optical module without any additional circuitry in between. **See page 4.**

<http://us.fujitsu.com/micro/10gethernet>



## MB8AA3020 20-Port, 10GbE Switch Chip in the Data Center

Two major trends – server virtualization and the rise of bladed servers – are driving demand for 10GbE in the data center. The Fujitsu MB8AA3020 20-port, 10GbE switch chip meets the needs of a virtualized bladed server data center. Its advantages: congestion management, quality of service (QoS), VLAN virtualization and physical-level properties. **See page 4.** <http://www.fujitsu.com/us/services/edevices/microelectronics/10datatech.html>

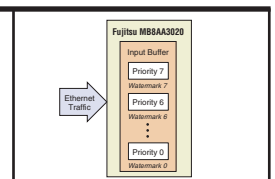

## The Fujitsu Mobile WiMAX SoC, MB86K21 802.16e

Fujitsu is announcing its specifications and roadmap for the Fujitsu MB86K21 802.16e mobile SoC at Broadband Wireless World. The mobile WiMAX SoC provides substantial performance enhancements for media-rich PC applications in mobile environments, and power consumption and latency performance improvements over comparable market alternatives, in a compact form factor. The device is targeted to be the first in its class to

participate in WiMAX Forum Wave 2 certification. Samples will be available in this August.

The Fujitsu mobile WiMAX SoC was developed by the same team that developed the baseband for 2G and 3G mobile handsets. The team expects to achieve the lowest power consumption for the mobile WiMAX class of device. The first test chip delivered 240mW at 18.6Mbps and, even

at the theoretical highest throughput of 45Mbps DL, the power draw will be far less than 500mW.

The Fujitsu mobile WiMAX SoC will be in the third and final plugfest for mobile WiMAX before Wave 2 certification this fall. Fujitsu also participated in the plugfest conducted by ETSI and AT4 Wireless last May in Sophia Antipolis, France. ■



### The new mobile WiMAX will include:

- All features required for WiMAX Forum Wave 2 mobile device certification
- Highly integrated 512/1024 FFT OFDMA PHY with integrated MAC processors
- Support for 5MHz and 10MHz channel bandwidths
- Adaptive modulation schemes (64QAM, 16QAM and QPSK)
- Security implementation based on AES-CCM
- Support for 2x2 STC/MIMO
- Support for antenna diversity
- USB 2.0 and card bus/PCI host interface support
- Small footprint FBGA package

## Kedah Selects the Fujitsu Fixed WiMAX SoC for 3.5GHz Wireless Systems in Russia

Fujitsu is providing its MB87M3550 fixed WiMAX SoCs to Kedah Electronics Engineering for Kedah's new AsterPlex+ WiMAX Customer Premises Units (CPE) and WiMAX base stations. Kedah plans to ship systems available in the 3.5GHz band this year, and to expand into 2.5GHz to 2.7GHz and 5.1GHz to 6.4 GHz bands thereafter. The first-generation AsterPlex+ products will be outdoor units, available with either integral or separate antennas, and supporting full QoS.

Kedah selected the Fujitsu SoC partially because of the company's leadership in WiMAX technology, open technical policy, comprehensive hardware and software documentation, and aggressive reference design pricing. Other factors include the fact that Kedah can develop its own MAC layer using fee-free software modules from

Fujitsu, and that the Fujitsu Reference Design is compatible with a wide range of RF reference boards.

For fixed applications, the Fujitsu WiMAX SoC supports channel bandwidths from 1.75MHz to 20MHz, and can operate in either TDD or FDD mode. When using 64QAM modulation in a 20MHz channel and all 192 sub-carriers, the SoC data rate can reach up to 75Mbps. The Fujitsu SoC incorporates sophisticated processing power, including a powerful main RISC engine that implements the 802.16 upper-layer MAC, scheduler, drivers, protocol stacks and user application software. A secondary RISC/DSP



co-processor executes lower-layer MAC functions, offloading processing from the upper-layer MAC and improving total performance. ■

# A Whitepaper: Fixed WiMAX Applications Focus on IP Video Surveillance Networks

A new whitepaper discusses how fixed WiMAX technology is now enabling new applications that were previously limited by cost, distance and throughput. With the latest innovations, fixed wireless applications now securely go beyond mere short-range data communications. Superior outdoor performance, proven QoS and solid security enable WiMAX to support valuable multimedia applications like network video for surveillance. In addition, highly integrated WiMAX semiconductors like SoC and RFIC (Radio Frequency Integrated Circuit) significantly reduce on-board components and board size, lowering manufacturing costs. The open standard will also help speed market adoption, resulting in higher volume

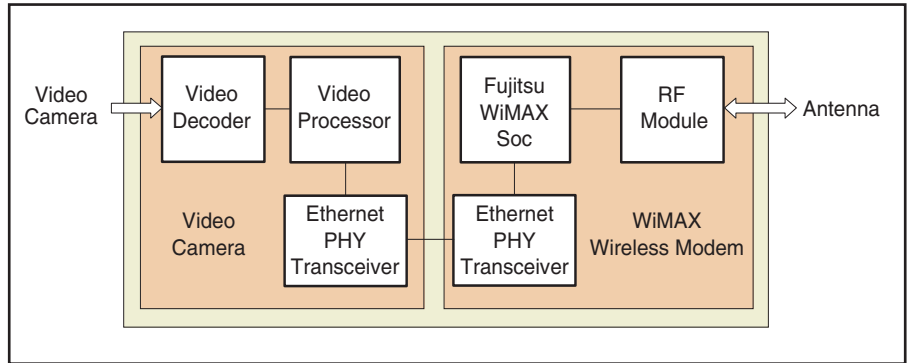

WiMAX-based Wireless IP Video Surveillance Camera Reference Design

demands. Read the full copy, including a representative surveillance camera reference design, at:

<http://www.fujitsu.com/us/services/edevices/microelectronics/wipvideo.html>

## The Fujitsu 20-port, 10GbE Switch Chip

The Fujitsu MB8AA3020 20-port, 10GbE switch chip delivers 400+Gbps non-blocking, aggregate switching bandwidth with high QoS capability. State-of-art VLAN virtualization, backward congestion management notification (BCN) and priority-based PAUSE make the chip suitable for data centers and carrier networks. Wirespeed switching at full cross-sectional bandwidth is achieved

through a proprietary, multi-stream, 3Mbyte shared-buffer memory. Users can choose either the on-chip 10Gbps serial PHYs, which minimize connectivity for XFP modules, or the on-chip PHYs for a CX-4 interface, with hardware adaptive equalization. Performance, combined with the smallest-in-class footprint and low power consumption, makes this device well-suited for server blade applications

as well as other bladed configurations like microTCA, ATCA blade and carrier blade applications. ■



## Teranetics, Teak and CorEdge Showcase Leading-Edge 10Gbps Ethernet

Teranetics, a leader in advanced mixed signal technology, will demonstrate its TN1010 10GBASE-T PHY, which uses the Fujitsu 10GbE switch chip embedded in the Fujitsu XG1200 switch box. The Teranetics 10GBASE-T PHY allows low-cost interconnects for 10GbE over category 6 twisted pair copper wire. The TN1010

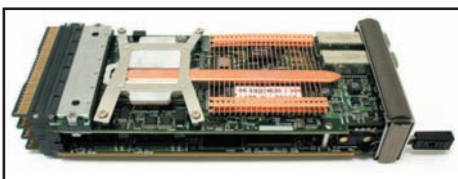

10GBASE-T PHY has full XAUI interface support for 10GBASE-T applications in next-generation NICs and switches for servers, enterprise networks and storage appliances.

Teak Technologies, a pioneer of 10Gbps congestion-free switching solutions, will showcase its switch module for IBM blade servers. The Fujitsu 10Gbps switch chip enables the Teak switch to provide congestion-free Ethernet operation. The 13000 is the first in a new category of scalable congestion-free Ethernet switching solutions for the new data center.

CorEdge Networks, a leading provider of key building blocks for MicroTCA/ATCA platforms, will feature its 10GbE fabric daughter card, the CEN-FAB10GE, as part of its MicroTCA Carrier Hub (MCH) module family. The CEN-FAB10GE permits full 10Gbps processing speed in a MicroTCA form factor, when added to the CEN-MCH base card supporting 1GbE base channel switching. The CEN-FAB10GE is based on the Fujitsu 20-port, 10GbE switch chip. ■

## Gennum and Fujitsu Demonstration at Interop West 2007

Gennum and Fujitsu are jointly demonstrating SFP+ capability using the Fujitsu 20-port, 10GbE switch chip and Gennum's CDR ICs. The innovative 10Gbps serial interconnect, based on the Fujitsu MB8AA3020, connects directly to an SFP+ optical module without any additional circuitry in between. Gennum and Fujitsu are jointly demonstrating SFP+ capability using the Fujitsu 20-port, 10GbE switch chip and Gennum's CDR ICs. The innovative 10Gbps serial interconnect, based on the Fujitsu MB8AA3020, connects directly to an SFP+ optical module without any additional circuitry in between. Gennum's

CDR solution, comprised of the 10Gigabit Ethernet GN2023 and GN2024 CDRs, is optimized to work with high integration ICs, such as Fujitsu's, and supports modules, such as the 10GBASE-SR compliant SFP+ optical transceiver being demonstrated, that enable higher density linecard designs.

Gennum's latest CDR solution, comprised of the second-generation GN2023 Limiting Amplifier plus CDR IC and the GN2024 Equalizer plus CDR IC, can be utilized in both XFP and SFP+ optical modules supporting 10Gbps Ethernet applications;

both devices operate from a 3.3V supply and do not require a reference. The CDR solution is based on Gennum's ClearEdge™ technology, which offers enhanced performance and reduced power consumption. ■

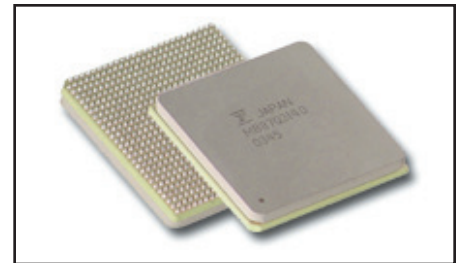

## Benefits of the MB8AA3020 20-Port, 10GbE Switch Chip in the Data Center

Two major trends – server virtualization and the rise of bladed servers – are driving demand for 10GbE in the data center.

Traditionally, servers in the data center have been dedicated to single applications like web hosting, storage, databases and cluster computing. This has led to a proliferation of physical servers, resulting in poor server utilization.

Virtualization improves server utilization by allowing multiple virtual machines to run on the same physical server. Server consolidation and virtualization now require bandwidth far in excess of a single GbE link, or even multiple GbE links that act as a link aggregation group.

Higher server density also drives adoption of 10GbE in the data center. The move from traditional 1U rack-mounted servers to highly integrated, high-density bladed servers is now well underway, requiring a corresponding increase in bandwidth.

The only viable solution to these increased bandwidth requirements is to boost availability from a single GbE link to a full

10GbE, alleviating the bottleneck experienced in the physical server. Most server blades today support GbE data rates but, in the bladed environment, migration to 10GbE is no longer a luxury. It's a necessity.

The Fujitsu 20-port, 10GbE switch chip was specifically designed to meet the needs of a virtualized bladed server data center. The chip's advantages lie in four areas: congestion management, quality of service, VLAN virtualization and physical-level properties.

The MB8AA3020 switch chip also offers inherent physical advantages, which make it ideal for the data center:

- CX4/XAUI/XFI configurability on all ports
- Lowest available latency
- Lowest available power consumption
- Smallest available footprint

This article was based on a new technical backgrounder entitled "Benefits of the MB8AA3020 20-port, 10GbE Switch Chip in the Data Center," which is available at <http://www.fujitsu.com/us/services/edevice/microelectronics/10gdatatech.html>

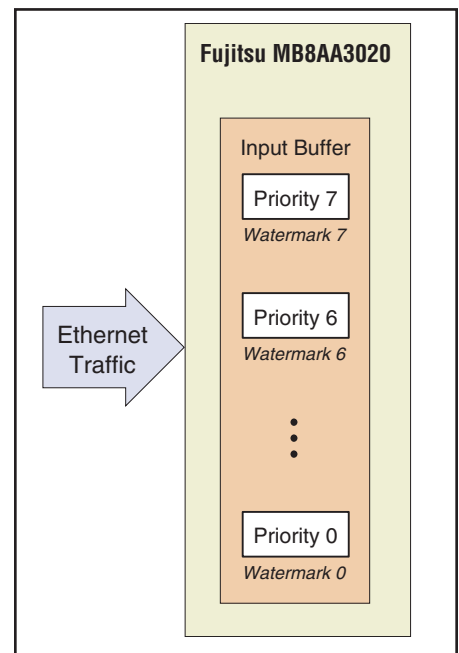

Setting Watermarks on a Per-Priority Basis on the MB8AA3020

### FUJITSU MICROELECTRONICS AMERICA, INC.

1250 E. Arques Avenue, MS333, Sunnyvale, CA 94088-3470

Tel: (800) 866-8608 Fax: (408) 737-5999

<http://us.fujitsu.com/micro>, Email: [inquiry@fma.fujitsu.com](mailto:inquiry@fma.fujitsu.com)